

3D MODEL GUIDE		
RANGE	DT PNEUMATIC PUSH	
	AXIAL	R/A
2mm	DT2P	DTR2P
5mm	DT5P	DTR5P
10mm	DT10P	DTR10P
10/2mm	DT10-2P	DTR10-2P
20mm	DT20P	DTR20P
30/5mm	DT30-5P	DTR30-5P
30/10mm	DT30-10P	DTR30-10P

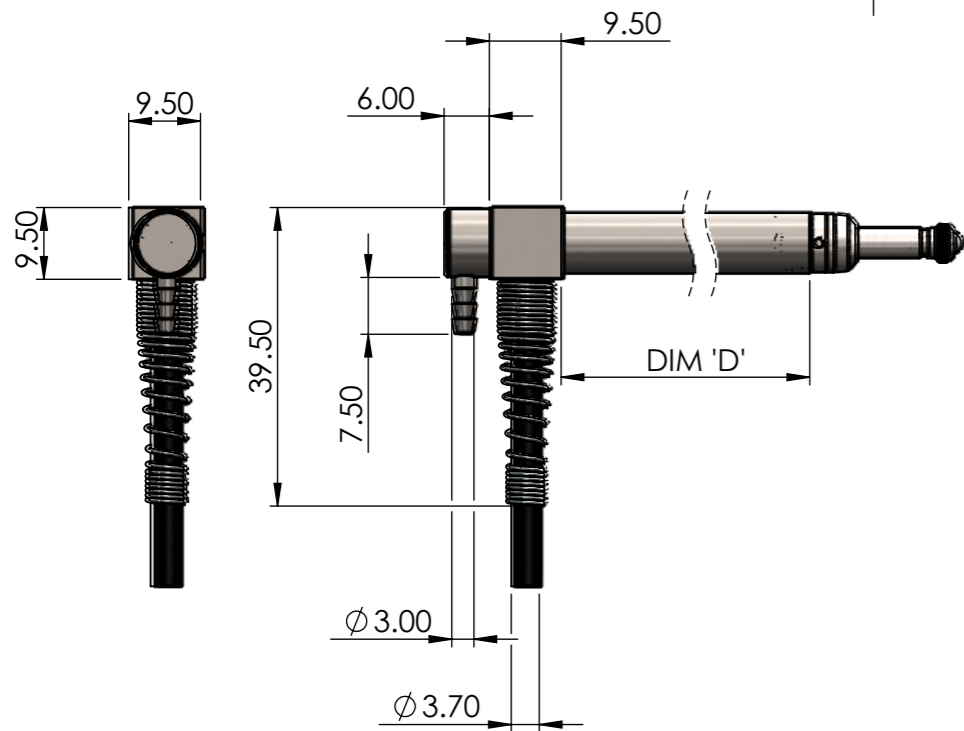
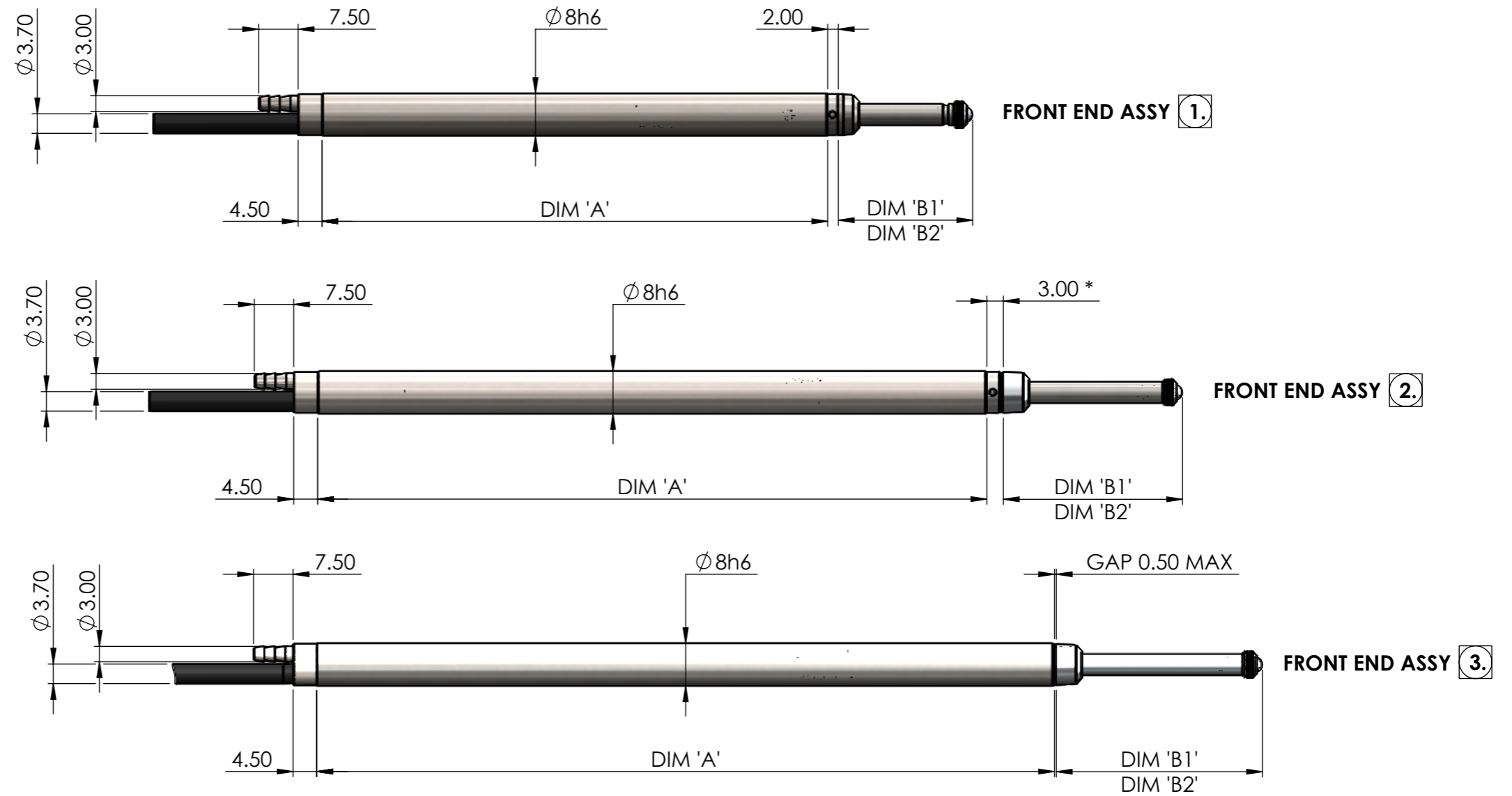

RADIAL CABLE OUTLET OPTION 'R/A'

MEASUREMENT RANGE	2mm	5mm	10mm	10/2mm	20mm	30/5mm	30/10mm
CASE LENGTH AXIAL DIM 'A'	52.50	71.00	96.00	84.00	127.00	140.00	145.00
CASE LENGTH R/A DIM 'D'	38.50	57.50	82.50	70.50	113.50	126.50	131.50
FULLY EXTENDED DIM 'B1'	14.25	18.00	25.50	25.50	34.00	39.25	39.25
PRE-TRAVEL	0.15	0.15	0.15	0.15	0.15	0.15	0.15
POST-TRAVEL	0.85	0.85	0.85	8.85	0.85	24.85	19.85
FULLY RETRACTED DIM 'B2'	11.25	12.00	14.50	14.50	13.00	9.25	9.25
FRONT END ASSY	①	①	①	①	②	③	③

NOTE: * - VARIABLE DIMENSION, TOLERANCE ±25mm.